

CATCH BASIN - 4'-0" DIA. (H-20) W/ 4 FT SUMP AND TAR COAT

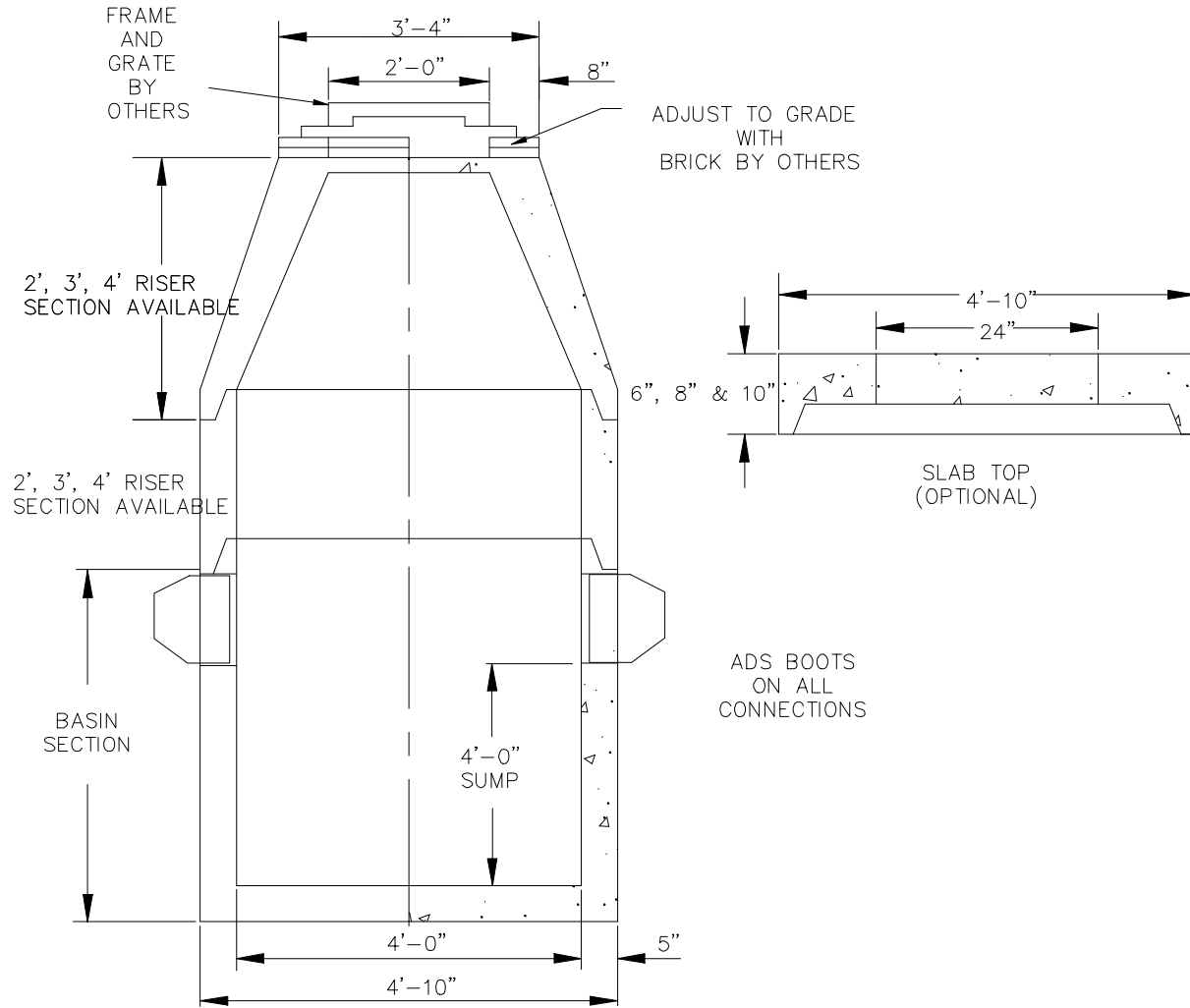

SPECIFICATIONS

- Concrete Minimum Strength: 5,000 P.S.I @ 28 days
- Steel Reinforcement: AS-615-68, Grade 60
- Design Loading: AASHTO - H-20 Meets ASTM Spec. C1227
- CS-55 Tar Coat applied for waterproofing