

# SEPTIC TANK - 1,000 GALLON (H-20)

ST-1000-H-20

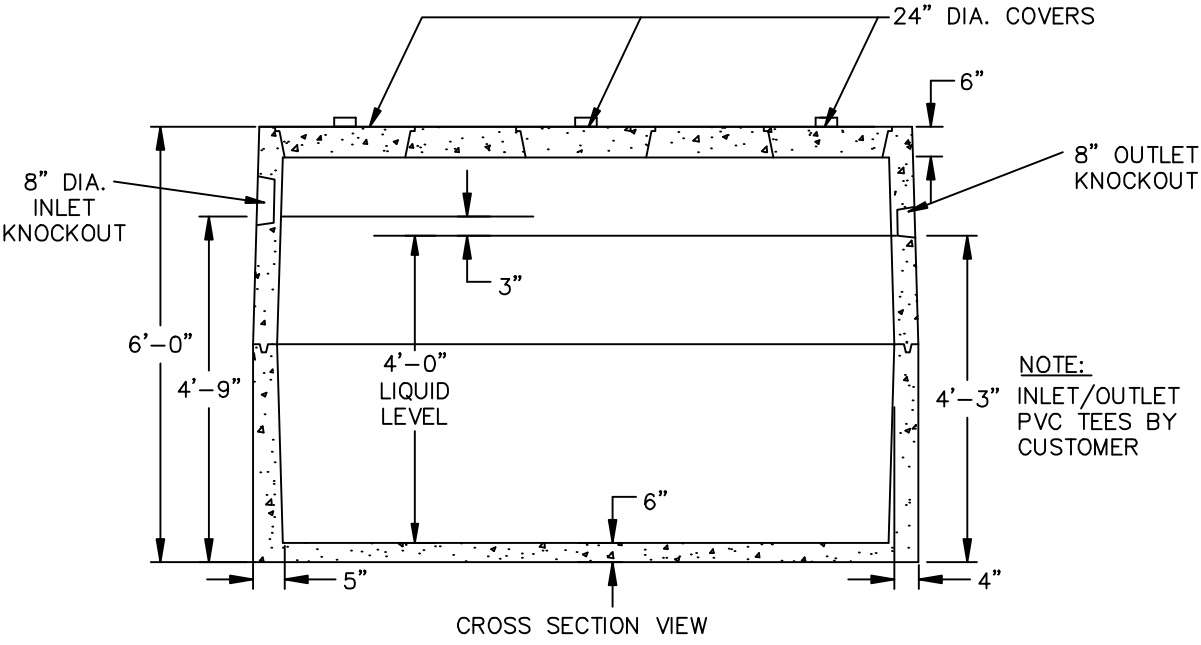
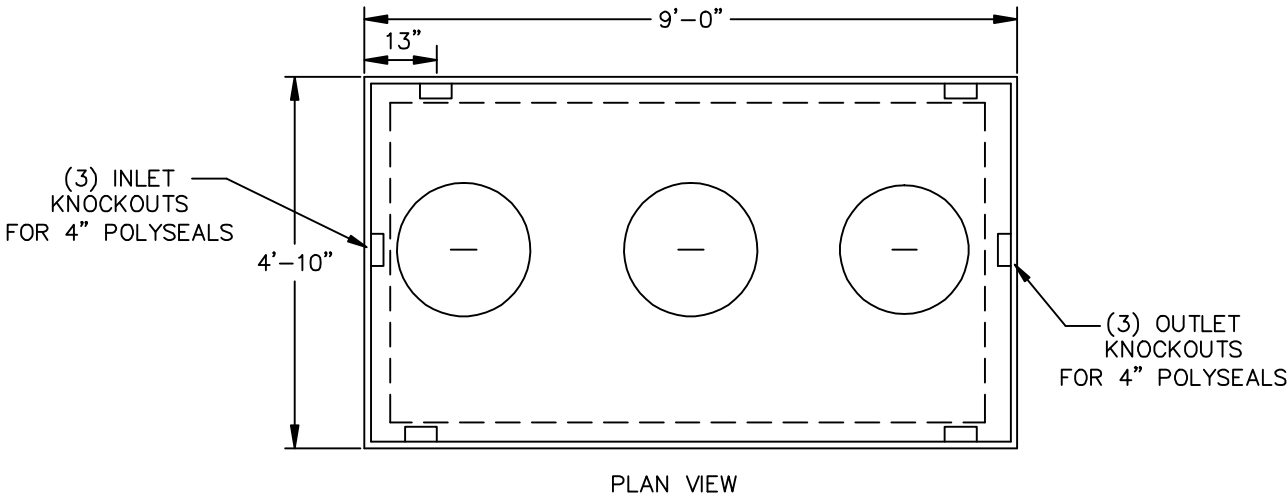

## SPECIFICATIONS

- Concrete Minimum Strength: 4,000 P.S.I @ 28 days
- Steel Reinforcement: AS-615-68, Grade 60
- Design Loading: AASHTO - H-20 Meets ASTM Spec. C1227
- Weight: 14,500 lbs.