

DISTRIBUTION BOX - DB-5 H-10 (3 INLET WITH BAFFLE)

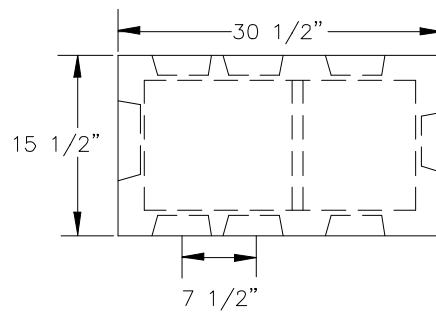

PLAN VIEW

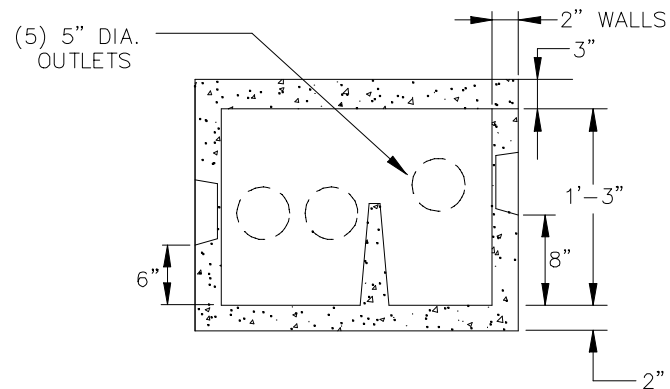

SECTION VIEW

SPECIFICATIONS

- Concrete Minimum Strength: 4,000 P.S.I @ 28 days
- Steel Reinforcement: AS-615-68, Grade 60
- Design Loading: AASHTO - H-10 Meets ASTM Spec. C1227
- Weight: 370 lbs.